

Senco

Maverick Hardware

Nails and Staples

Section O-2: Senco

Brad Nails 18 Gauge Medium Head

Part #	Description	Finish
SEAY10	5/8"	Galvanized
SEAY11	3/4"	Galvanized
SEAY13	1"	Galvanized

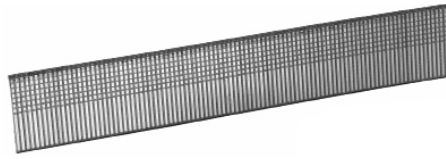

SENCO

Finish Nails 18 Gauge Headless Pins

Part #	Description	Finish
SEAZ08EAA	1/2"	Galvanized
SEAZ11EAA	3/4"	Galvanized
SEAZ13EAA	1"	Galvanized

SENCO

Staples 15 Gauge, Heavy Wire 7/16" Crown, Width .074, Thickness .067

Part #	Description	Finish
SEQ23BRB	2 1/4"	Bright



SENCO

Staples 19 Gauge, Medium Wire 1/4" Crown, Width .045, Thickness .030

Part #	Description	Finish
SEK08BABN	1/2"	Galvanized
SEK10BABN	5/8"	Galvanized
SEK11BAB	3/4"	Galvanized
SEK12BAB	7/8"	Galvanized
SEK13BABN	1"	Galvanized

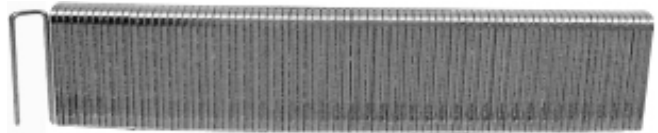

SENCO

Staples 22 Gauge, Fine Wire 3/8" Crown, Width .030, Thickness .0215

Part #	Description	Finish
SEC08BAAP	1/2"	Galvanized
SEC10BAAPN	5/8"	Galvanized



SENCO

Finish & Trim Staples 18 Gauge Medium Head Brad Nails

Part #	Description
SEAX10	5/8"
SEAX11	3/4"
SEAX13	1"
SEAX15	1 1/4"
SEAX16	1 3/8"
SEAX17	1 1/2"
SEAX18	1 5/8"
SEAX19	1 3/4"
SEAX21	2"
SEAX22	2 1/8"

SENCO

AX22EAA will only fit in the Senco FinishPro @25XP
Fasteners for ACQ – pressure treated lumber
Use stainless steel when maximum corrosion resistance is required.
Use hot dipped galvanized when lesser corrosion resistance is required.



Nails and Staples

Sheathing

16 Gauge, 7/16" Medium Crown



<u>Part #</u>	<u>Description</u>	<u>Finish</u>
SEN15BAB	1 1/4"	Galvanized
SEN17BAB	1 1/2"	Galvanized
SEN19BAB	1 3/4"	Galvanized
SEN21BAB	2"	Galvanized

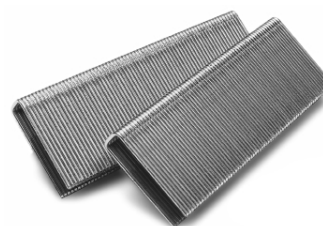

Fasteners for ACQ – pressure treated lumber
 Use stainless steel when maximum corrosion resistance is required.
 Use hot dipped galvanized when lesser corrosion resistance is required

Roofing / Heavy Staples

16 Gauge, 1" Wide Crown



<u>Part #</u>	<u>Description</u>	<u>Finish</u>
SEP11BAB	3/4" leg	Galvanized

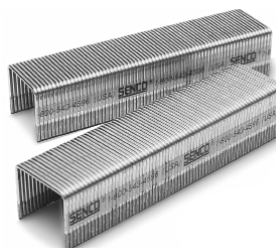

Fasteners for ACQ – pressure treated lumber
 Use stainless steel when maximum corrosion resistance is required.
 Use hot dipped galvanized when lesser corrosion resistance is required.

Finish & Trim Nails

15 Gauge



<u>Part #</u>	<u>Description</u>	<u>Finish</u>
SEDA13EPBN	1"	Bright
SEDA15EPBN	1 1/4"	Bright
SEDA17EPBN	1 1/2"	Bright
SEDA19EPBN	1 3/4"	Bright
SEDA21EPBN	2"	Bright
SEDA23EPBN	2 1/4"	Bright
SEDA25EPBN	2 1/2"	Bright
SEDA15EABN	1 1/4"	Galvanized
SEDA17EABN	1 1/2"	Galvanized
SEDA19EABN	1 3/4"	Galvanized
SEDA21EABN	2"	Galvanized
SEDA25EABN	2 1/2"	Galvanized



Fasteners for ACQ – pressure treated lumber
 Use stainless steel when maximum corrosion resistance is required.
 Use hot dipped galvanized when lesser corrosion resistance is required.

Finish & Trim Staples

16 Gauge T-Head Finish Nails



<u>Part #</u>	<u>Description</u>	<u>Finish</u>
SEM001001	1"	Galvanized
SEM001002	1 1/4"	Galvanized
SEM001003	1 1/2"	Galvanized
SEM001004	1 3/4"	Galvanized
SEM001005	2"	Galvanized
SEM001007	2 1/2"	Galvanized

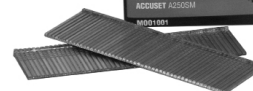

Fasteners for ACQ – pressure treated lumber
 Use stainless steel when maximum corrosion resistance is required.
 Use hot dipped galvanized when lesser corrosion resistance is required.

Maverick Hardware

Nails and Staples

Section O-2: Senco

Finish & Trim Staples

23 Gauge Micro Pins



Part #	Description	Finish
SEA100509	1/2"	Galvanized
SEA100629	5/8"	Galvanized
SEA100759	3/4"	Galvanized
SEA101009	1"	Galvanized

Finish & Trim Staples

18 Gauge Crown Staples, 1/4" Crown



Part #	Description	Finish
SEL06BAB	3/8" leg	Galvanized
SEL07BABP	7/16" leg	Galvanized
SEL08BAB	1/2" leg	Galvanized
SEL10BABN	5/8" leg	Galvanized
SEL11BAB	3/4" leg	Galvanized
SEL12BAB	7/8" leg	Galvanized
SEL14BAB	1 1/8" leg	Galvanized
SEL15BAB	1 1/4" leg	Galvanized
SEL17BAB	1 1/2" leg	Galvanized
SEL11BRB	3/4" leg	Bright
SEL13BRBN	1" leg	Bright
SEL14BRB	1 1/8" leg	Bright
SEL15BRB	1 1/4" leg	Bright

Staples 22 Gauge, Fine Wire

3/16" Crown, Width .030, Thickness .0215

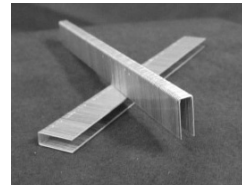

Part #	Description	Finish
SEA06BABP	3/8"	Galvanized
SEA08BABP	1/2"	Galvanized

Staples 20 Gauge, Fine Wire

3/16" Crown, Width .050, Thickness .019

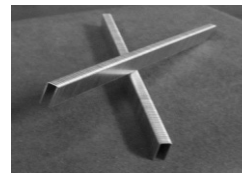

Part #	Description	Finish
SEE08BAA	1/2"	Galvanized
SEE10BAA	5/8"	Galvanized

Staples 20 Gauge, Fine Wire

1/2" Crown, Width .050, Thickness .019

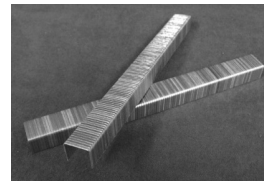

Part #	Description	Finish
SEF06BAA	3/8"	Galvanized

Staples 18 Gauge, Fine Wire

3/8" Crown, Width .050, Thickness .044



Part #	Description	Finish
SEM06BABN	3/8"	Galvanized
SEM08BAB	1/2"	Galvanized
SEM10BABN	5/8"	Galvanized
SEM11BABN	3/4"	Galvanized
SEM12BAB	7/8"	Galvanized
SEM13BAB	1"	Galvanized
SEM15BAB	1 1/4"	Galvanized

Nailers and Staplers

FinishPro ®32, 16 Gauge

SE.FP32

Uses 16 gauge finishing nails. 1 1/4" to 2 1/2".

Benefits

- Adjustable depth of drive
- Adjustable exhaust
- Belt hooks adjust for left or right hand users
- No mar pad to protect work surface
- One year warranty
- Includes case, fitting and oil

Applications include

- Finishing
- Hardwood flooring
- Molding and baseboards

SENCO



Section O-2: Senco

SFN 30, 15 Gauge Angled Finish Nailer

SE.SFN30

The SFN 30 drives 1" - 2" DA 15-gauge fasteners.

Benefits

- Never lube – no lubrication required
- Adjustable depth of drive allows for flush drive or precision countersinking at lower air pressure
- Light weight – 3.6 lbs
- Handy belt hook adjust for left or right hand users
- One year warranty
- Case included
- Adjustable depth of drive, exhaust belt hooks for left or right hand users
- No mar pad, over mold comfort grip, over mold trigger pad

Applications Include

- Construction
- Furniture and cabinets
- Picture frames
- Nailable plastic parts

SENCO



SLP20, 18 Gauge Finish Nailer

SE.SLP20

Fastener range: drives slight head 18 gauge brads from 5/8" - 1" and medium head brads from 1" - 1 5/8"

Benefits

- Maneuverable and light weight
- Never lube – no lubrication required
- Easy to maintain and service – only (2) moveable O-rings for trouble free upkeep
- Easy side leading that allows you to change brad length without adjusting tool, plus EZ clear jam clearance
- One year warranty

Applications include

- Molding and trim
- Window beading
- Furniture, rattan
- Cabinets and drawers

SENCO

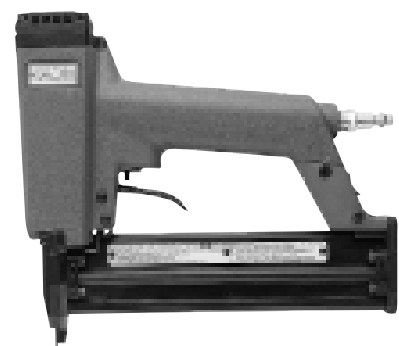

Maverick Hardware

Nailers and Staplers

Section O-2: Senco

FinishPro® 18 Gauge Brad Nailer

SE.FP25XP

Finish Pro drives slight and medium head 18 gauge brads from 5/8" to 2 1/8".

Benefits

- Rugged internal engine design for "Xtreme Pro"
- Never lube – no lubrication required
- On tool power adjustment with wrenches on tool for fast adjustments
- Five year warranty

Applications include

- Molding and trim
- Window beading
- Blind pinning, rattan
- Cabinets and drawers

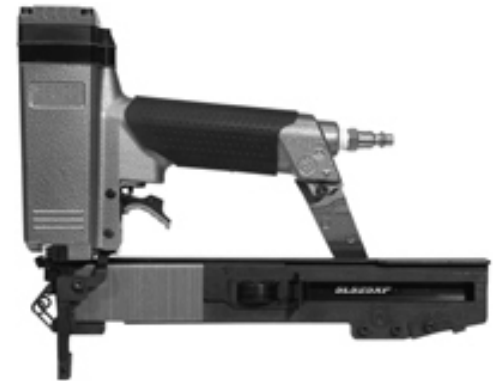

SENCO

FinishPro® 10, 23 Gauge

SE.FP10

The micro pins fasten the smallest trim securely leaving nearly an invisible hole
Finish Pro drives 23 gauge, headless pins from 1/2" - 1" in length.

Benefits

- Rear exhaust
- Easy fastener length adjustment
- Low load brad indicator
- Comfort tool grip
- Extra power for use in hardwoods
- Includes case, fitting and oil
- One year warranty

Applications include

- Cabinet doors
- Small trim
- Glazing bead, carvings and ornamentals



SENCO

SLS25XP, Xtreme Pro 18 Gauge Medium Wire Stapler

SE.SLS25XP-L ((L 1/4" L06 - L17)

SE.SLS25XP-M (M Wire M06 – M 17)

Fastener range 1/4" and 3/8" crown. With lengths from 3/8" to 1 1/2" lengths.

Benefits

- Lightweight (2.7lbs)
- Adjustable depth of drive for precise countersinking
- Rugged for internal engine design for "Xtreme Pro"
- No lube design
- No mar nose pad
- Case included
- Five year warranty

Applications include

- Cabinets and drawers
- Cabinet frame assembly
- Underlayment sheathing
- Molding and trim
- Soffits
- Prefinished gypsum and siding

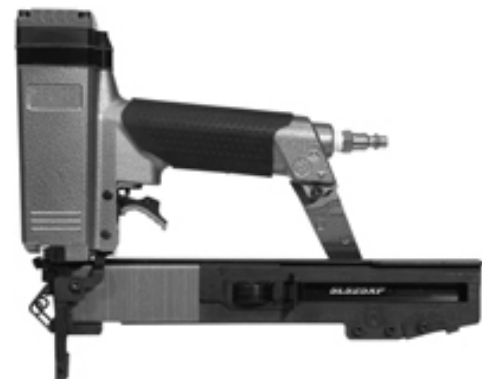

SENCO

Lubricants

Lubricants

SE.PC0101

Pneumatic Tool Oil

SENCO



Section O-2: Senco